

DETAIL

SEMIAUTOMATIC COMBINED BEVELING MACHINE

Description:

The semiautomatic combined beveling machine has been projected for 45° chamfer execution on aluminium sheets „T” profiles .

The combined action of cutting and punching gives speed and precision on chamfer execution.

Very intuitive and convenient system of manual manipulation makes it particularly easy to use.

Technical Details:

- max lenght sheets 12.000mm.

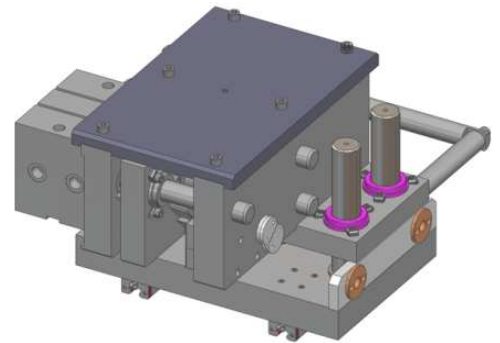

- min. depth sheets: 30mm
- max depth sheets: 90mm

Any customization can be engined and implemented case by case on request.

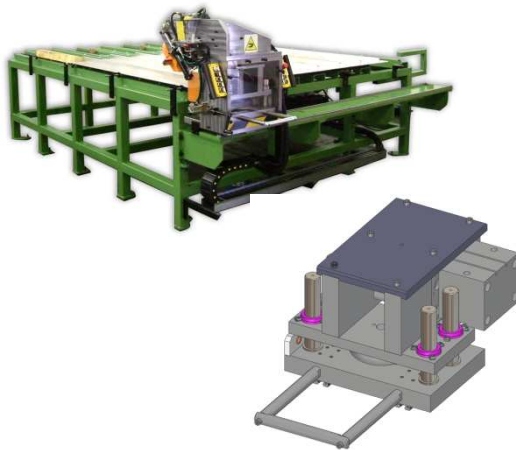

FINISHED PRODUCT



TECHNICAL DETAILS:	
Max lenght sheet	12.000 mm
Max depth sheet	90mm
Min depth sheet	30mm